

20/21
PRODUCTS

Product Catalogue

Aluminum Grill

Type (ALG)



Khedr Trust
ALL AIR PRODUCTS

Aluminum Grill products are
manufactured by



“Your comfort is
our priority”

www.khedr-eg.com



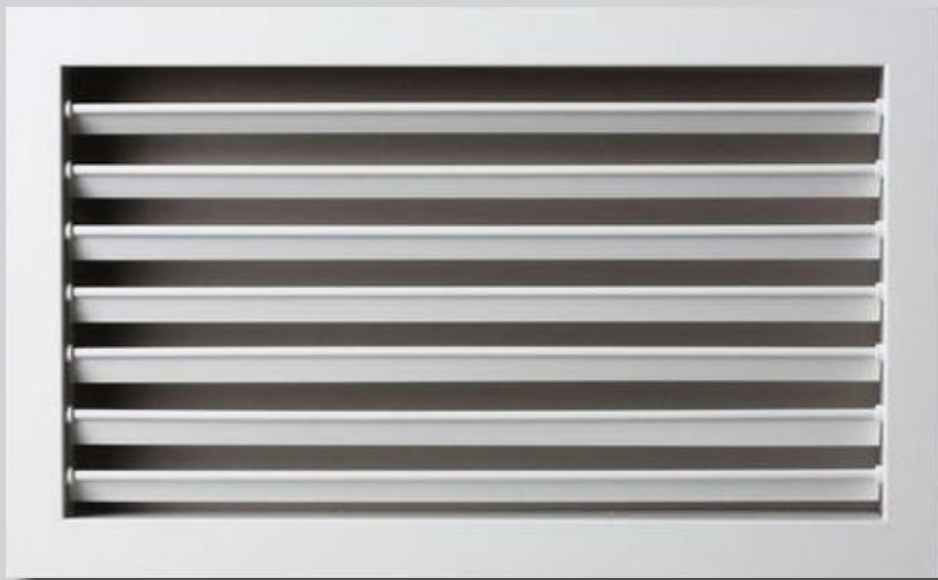

Models

- ALG-S "Single Deflection Grill"
- ALG-D "Double Deflection Grill"
- ALG-C "Horizontal Curved Blades"



Features

- Frame and blades are extruded aluminum alloy.
- Overlap margin 11/8 inch wide.
- Extruded aluminum blades on 3/4 inch center.
- Optional opposed blade damper can be used for supply applications.



Aluminum Grill

Model Design

Khedr Supply & Return Grills are designed ventilation applications.

Appearance

They are found in single deflection with horizontal or vertical face blades, also in double deflection.

Model Types

For supply applications can be provided with volume damper to control the amount of air.

- Construction

- A. Type (ALG-S) - Single Deflection

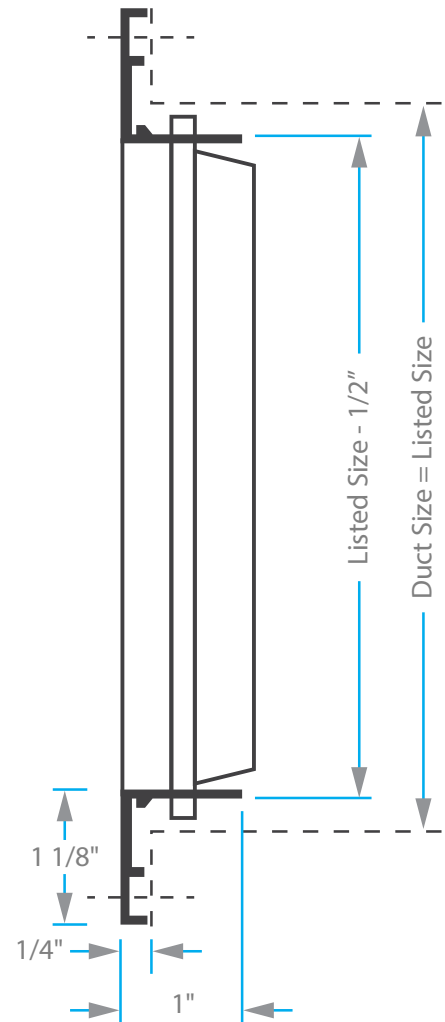
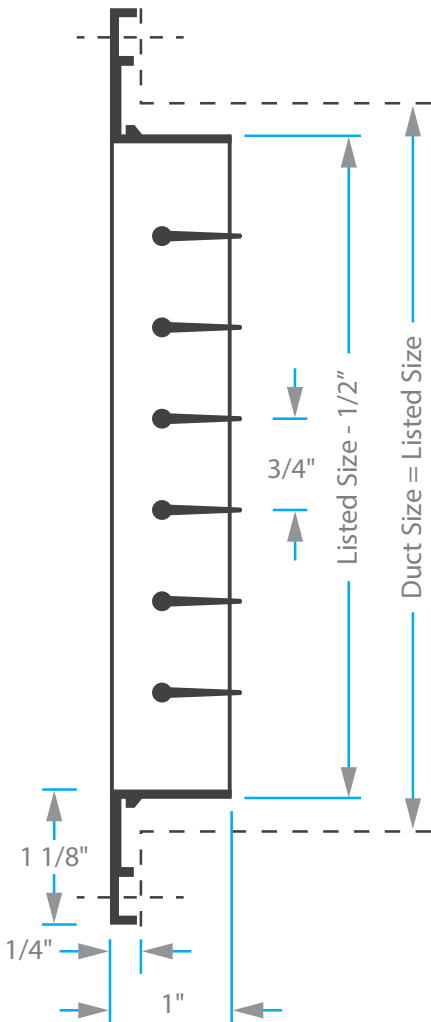
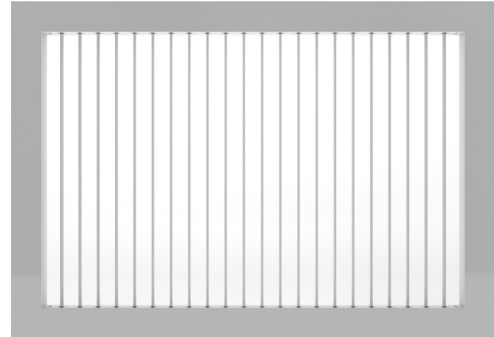

- B. Type (ALG-D) - Double Deflection

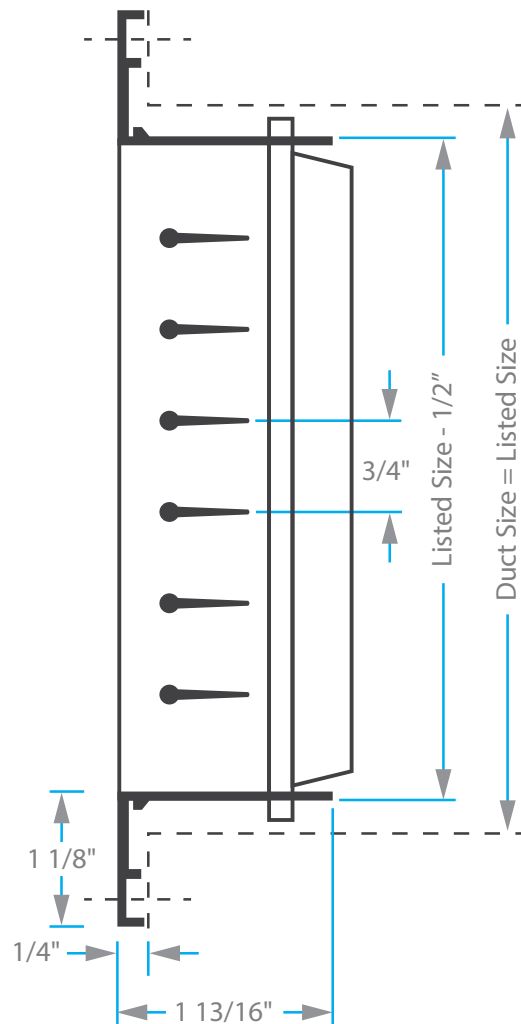
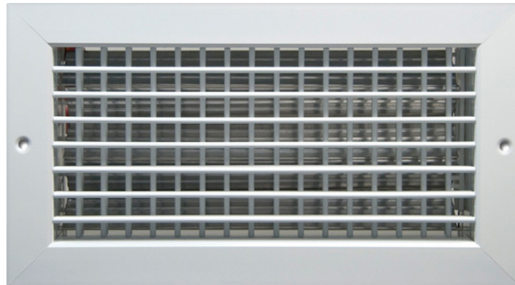

- C. Type (ALG-C) - Horizontal Curved Blades

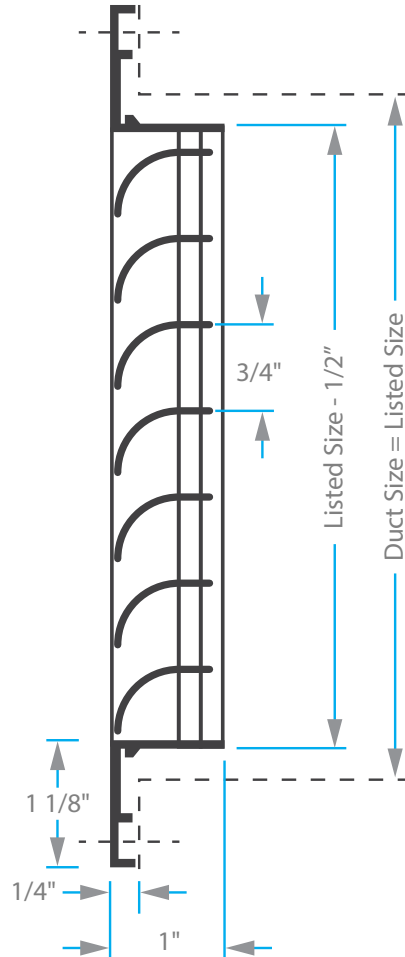
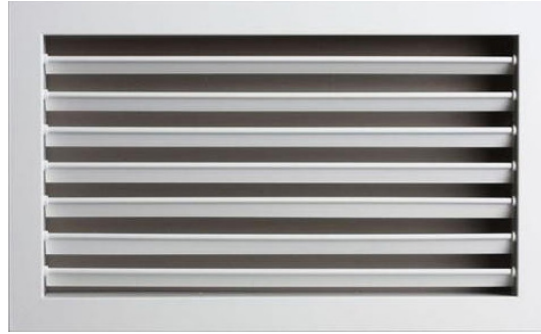

- Performance Data

	≥ NC 45
	NC 40
	NC 35
	NC 30

Listed Height (H)											CFM	Deflection				CFM	Deflection			
												0°	22°	42°	55°		0°	22°	42°	55°
Listed Width (W)											CFM	V _K				CFM	V _K			
												450	500	550	600		550	600	650	700
Listed Width (W)											CFM	P _T				CFM	P _T			
												0.01	0.01	0.02	0.02		0.02	0.02	0.03	0.03
Listed Width (W)											CFM	T				CFM	T			
												4	5	6	8		8	7	6	4
4	5	6	8	10	12	14	16	18	20	24	40	6	5	4	3	45	8	7	6	4
6	5										50	7	6	5	4	60	9	11	6	5
8	6										75	9	7	6	5	90	10	9	7	6
10	8	6									100	10	8	6	5	125	11	9	8	7
12	10	8									125	11	9	7	6	150	12	11	9	7
14	12	10	8								150	11	10	8	7	175	13	11	10	8
18	14	12									175	12	11	9	7	200	15	13	11	9
20	16	14	10								225	13	12	10	8	275	16	14	12	10
24	20	16	12	10							300	14	13	11	9	350	18	15	13	10
30	24	20	14	12							350	17	14	12	9	425	20	17	13	11
38	30	24	18	14	12						400	18	16	13	10	475	21	18	15	12
40	32	26	20	16	14						450	19	17	13	11	550	22	19	17	13
44	36	30	24	18	16	14					500	20	17	14	12	600	24	20	18	13
	44	36	26	22	18	16					600	21	18	15	12	700	25	22	18	14
	48	40	30	24	20	18	16				700	23	20	17	13	850	28	24	20	15
		48	38	30	24	22	18				800	25	21	18	14	950	31	26	22	17
			40	32	28	24	20	18			900	27	22	19	15	1100	32	27	23	18
			42	36	30	26	24	22	20		1000	29	25	21	16	1200	34	29	25	19
			46	42	36	30	26	24	22		1250	32	27	23	18	1500	36	30	27	23
					44	38	34	30	28	24	1500	34	29	25	19	1800	39	32	29	25
						48	42	36	34	28	1750	37	32	27	21	2100	42	35	32	27
							44	40	36	30	2000	39	34	29	22	2400	45	38	34	29
								48	42	36	2250	41	36	30	24	2700	48	40	36	31
									48	40	2500	43	38	32	25	3000	51	42	38	33
										48	3000	46	40	34	27	3600	54	45	40	35

Aluminum Grill products are manufactured by Khedr Trust Co.

The T Dimensions in feet is based on a V_T of 150 FPM.

- V_T Terminal Velocity "FPM" T Throw "Feet"
- V_K Outlet Velocity "FPM" P_T Total Pressure "Inch Water"

	NC 45
	NC 40
	NC 35
	NC 30

Listed Height (H)											CFM	Deflection				CFM	Deflection			
												0°	22°	42°	55°		0°	22°	42°	55°
Listed Width (W)											CFM	V _K				CFM	V _K			
												600	700	750	800		700	800	900	1000
Listed Width (W)											CFM	P _T				CFM	P _T			
												0.02	0.03	0.04	0.04		0.03	0.04	0.05	0.06
Listed Width (W)											CFM	T				CFM	T			
4	5	6	8	10	12	14	16	18	20	24	60	10	9	7	5	65	11	10	8	6
6	5										70	11	10	8	6	80	12	11	9	7
8	6										100	12	11	9	7	125	13	12	10	8
10	8	6									150	13	12	9	8	175	14	13	11	8
12	10	8									175	14	13	10	8	200	16	14	11	9
14	12	10	8								200	15	14	11	9	250	17	15	12	10
18	14	12									250	17	15	12	9	275	19	17	14	11
20	16	14	10								300	19	16	13	10	350	21	18	15	12
24	20	16	12	10							425	20	17	15	11	475	24	20	17	13
30	24	20	14	12							500	22	20	17	12	550	26	22	18	14
38	30	24	18	14	12						550	24	21	18	13	650	28	24	20	15
40	32	26	20	16	14						625	26	22	19	14	725	30	25	22	17
44	36	30	24	18	16	14					700	27	24	20	15	800	32	27	23	18
	44	36	26	22	18	16					850	29	25	22	16	950	34	29	25	19
	48	40	30	24	20	18	16				975	33	28	24	18	1125	37	31	27	21
		48	38	30	24	22	18				1125	35	30	26	20	1275	39	34	29	22
			40	32	28	24	20	18			1250	36	31	27	21	1450	42	36	31	23
			42	36	30	26	24	22	20		1400	40	34	29	22	1600	45	39	34	25
			46	42	36	30	26	24	22		1750	43	37	31	24	2000	48	43	36	27
					44	38	34	30	28	24	2100	45	40	34	26	2400	52	46	39	30
						48	42	36	34	28	2450	48	44	37	28	2800	55	49	42	32
							44	40	36	30	2800	52	46	40	30	3200	58	52	44	34
								48	42	36	3150	54	48	42	32	3600	61	54	46	37
									48	40	3500	57	51	44	33	4000	64	57	49	39
										42	4200	60	53	47	35	4800	68	60	52	42

Aluminum Grill products are manufactured by Khedr Trust Co.

The T Dimensions in feet is based on a V_T of 150 FPM.

- V_T Terminal Velocity "FPM"
- V_K Outlet Velocity "FPM"
- T Throw "Feet"
- P_T Total Pressure "Inch Water"

	≥ NC 45
	NC 40
	NC 35
	NC 30

Listed Height (H)											CFM	Deflection				CFM	Deflection			
												0°	22°	42°	55°		0°	22°	42°	55°
Listed Width (W)											V _K				V _K					
											900	1000	1100	1200	1100	1200	1300	1400		
											P _T				P _T					
											0.05	0.06	0.08	0.09	0.08	0.09	0.10	0.13		
											T				T					
4	5	6	8	10	12	14	16	18	20	24	80	13	11	9	7	100	15	13	11	8
6	5										100	15	13	11	8	125	18	15	13	10
8	6										150	17	14	12	9	175	20	17	14	11
10	8	6									200	18	15	13	10	250	22	19	15	12
12	10	8									250	21	18	15	11	300	25	21	18	14
14	12	10	8								300	24	20	16	13	350	27	24	20	15
18	14	12									350	25	21	18	14	425	30	25	21	17
20	16	14	10								450	27	23	19	15	550	32	28	24	18
24	20	16	12	10							600	29	25	21	16	725	35	30	26	20
30	24	20	14	12							700	32	28	24	18	850	39	33	28	21
38	30	24	18	14	12						800	34	30	25	19	950	41	35	30	22
40	32	26	20	16	14						900	36	31	26	20	1075	43	37	32	24
44	36	30	24	18	16	14					1000	39	33	28	22	1200	45	40	34	26
	44	36	26	22	18	16					1200	42	36	31	24	1450	48	42	36	28
	48	40	30	24	20	18	16				1400	45	39	34	26	1675	52	45	40	31
		48	38	30	24	22	18				1600	47	43	37	28	1925	56	48	43	34
			40	32	28	24	20	18			1800	49	44	40	31	2150	59	51	46	35
			42	36	30	26	24	22	20		2000	52	47	42	32	2400		54	49	38
			46	42	36	30	26	24	22		2500	56	50	45	34	3000		59	53	41
					44	38	34	30	28	24	3000	50	54	48	36	3600			58	44
						48	42	36	34	28	3500		59	53	40	4200				49
							44	40	36	30	4000			57	43	4800				54
								48	42	36	4500			60	45	5400				58
									48	40	2500				49					
										48	6000				54					

Aluminum Grill products are manufactured by Khedr Trust Co.

The T Dimensions in feet is based on a V_T of 150 FPM.

- V_T Terminal Velocity "FPM"
- V_K Outlet Velocity "FPM"
- T Throw "Feet"
- P_T Total Pressure "Inch Water"

	≥ NC 45
	NC 40
	NC 35
	NC 30

Listed Height (H)											Deflection				Deflection					
											0°				22°				42°	
Listed Width (W)											V _K				V _K					
											1250	1400	1550	1700	1450	1600	1750	1900		
											P _T				P _T					
											0.09	0.12	0.15	0.18	0.13	0.16	0.19	0.23		
											T				T					
4	5	6	8	10	12	14	16	18	20	24	125	19	16	13	10	150	22	19	15	12
6	5										150	21	18	14	11	175	25	21	17	13
8	6										200	24	20	17	13	225	27	23	19	15
10	8	6									275	25	21	18	14	325	29	25	21	17
12	10	8									350	28	25	20	15	400	33	28	24	18
14	12	10	8								425	31	27	22	17	475	36	32	26	20
18	14	12									500	34	30	25	19	550	39	32	27	21
20	16	14	10								625	37	32	27	22	725	42	36	31	24
24	20	16	12	10							850	41	35	30	23	950	45	40	34	26
30	24	20	14	12							975	45	39	33	25	1125	49	43	38	28
38	30	24	18	14	12						1125	48	41	35	27	1275	52	46	40	31
40	32	26	20	16	14						1250	51	43	37	28	1450	55	49	42	32
44	36	30	24	18	16	14					1400	53	45	39	30	1600	58	51	44	34
	44	36	26	22	18	16					1675	57	48	42	32	1925	61	54	46	36
	48	40	30	24	20	18	16				1950	60	51	45	35	2250		58	49	40
		48	38	30	24	22	18				2250		54	47	39	2500		62	53	43
			40	32	28	24	20	18			2500		57	50	41	2750			56	46
			42	36	30	26	24	22	20		2800		61	53	43	3200			59	48
			46	42	36	30	26	24	22		3500			58	47	4000				54
					44	38	34	30	28	24	4200				52	4800				59
						48	42	36	34	28	4900				56					
							44	40	36	30	5600				60					
								48	42	36										
									48	40										
										42										
										48										

Aluminum Grill products are manufactured by Khedr Trust Co.

The T Dimensions in feet is based on a V_T of 150 FPM.

- V_T Terminal Velocity "FPM"
- V_K Outlet Velocity "FPM"
- T Throw "Feet"
- P_T Total Pressure "Inch Water"

- Selection Procedure

1. Determine the required CFM per each outlet as per cooling Load Calculation.
2. Determine the type of Grill.
Example : "Horizontal Single Deflection , Perforated ,...etc "
3. Determine the recommended Outlet Velocity V_K according to application as per following Table.
4. Select width and the length of air outlet that give the required CFM at recommended outlet velocity from performance data tables.

Application	V_K Outlet Velocity "FPM"
Broadcast Studios	300-500
Residences	500-750
Apartments	500-750
Mosques , Churches	500-750
Hotel Bedrooms	500-750
Theaters	500-750
Private Offices, Acoustically Treated	500-750
Private Offices, not Treated	500-800
General Offices	1000-1250
Dept. Stores	1500

Aluminum Grill products are manufactured by Khedr Trust Co.

Table (1) – Recommended Outlet Velocity *

* Table 20—Carrier Handbook – Part 2. Air Distribution – Chapter 3. Room Air Distribution—p.72

- Selection Procedure Example

1. Required 500 CFM as per cooling load calculations.
2. Required Double Deflection.
3. The recommended outlet velocity ranges from 500 - 750 FPM & Throw = 18 ft.
4. The size of air outlet can 14 X 16 at 450 FPM with 0° deflection.

Listed Height (H)											Deflection				Deflection					
											0°	22°	42°	55°	0°	22°	42°	55°		
Listed Width (W)											CFM	V _K				CFM	V _K			
												450	500	550	600		550	600	650	700
											CFM	P _T				CFM	P _T			
												0.01	0.01	0.02	0.02		0.02	0.02	0.03	0.03
											CFM	T				CFM	T			
												0.01	0.01	0.02	0.02		0.02	0.02	0.03	0.03
4	5	6	8	10	12	14	16	18	20	24	40	6	5	4	3	45	8	7	6	4
6	5										50	7	6	5	4	60	9	11	6	5
8	6										75	9	7	6	5	90	10	9	7	6
10	8	6									100	10	8	6	5	125	11	9	8	7
12	10	8									125	11	9	7	6	150	12	11	9	7
14	12	10	8								150	11	10	8	7	175	13	11	10	8
18	14	12									175	12	11	9	7	200	15	13	11	9
20	16	14	10								225	13	12	10	8	275	16	14	12	10
24	20	16	12	10							300	14	13	11	9	350	18	15	13	10
30	24	20	14	12							350	17	14	12	9	425	20	17	13	11
38	30	24	18	14	12						400	18	16	13	10	475	21	18	15	12
40	32	26	20	16	14						450	19	17	13	11	550	22	19	17	13
44	36	30	24	18	16	14					500	20	17	14	12	600	24	20	18	13
	44	36	26	22	18	16														

Aluminum Grill products are manufactured by Khedr Trust Co.

- How to order

Type	ALG-S	ALG-S "Single Deflection Grill " ALG-D "Double Deflection Grill " ALG-C "Horizontal Curved Blades" ALG-P "Perforated Grill "
Orientation	H	H Horizontal Face Blades V Vertical Face Blades
Size	24 x 24	Size "Inch"
Finish	1	0 Aluminum 1 White Color 2 Other Colors
Damper	0	0 Without Damper 1 With Damper in Inlet collar

Aluminum Grill products are manufactured by Khedr Trust Co.

Other Products are provided by Khedr Trust Co.

Diffusers & Grills

Slot Linear Diffuser
Eye Ball Diffuser
Circular Ceiling Diffuser
Swirl Diffuser
Perforated Ceiling Diffuser
Jet Diffuser
Square Ceiling Diffuser
Disc Valve Diffuser
Linear Bar Grill
Supply / Return Grill
Door Grill

Louvers

Aluminum Louver
Sand Trap Louver

Dampers

Volume Damper
Fire Damper
Smoke Motorized Damper
Shutter Damper
Pressure Relief Damper

Special Parts

Sound Attenuator
Plenum Box

Duct Works

Galvanized Steel Duct
Black Steel Duct
Stainless Steel Duct
Spiral Duct
Flexible Duct
Canvas
Flanges
Flexible Duct Connector



Khedr Trust

ALL AIR PRODUCTS



Alqanater Alkhairia roads.Industrial Area. Behind Cocacola Co.. Cairo, Egypt

Mailing Address : P.O.Box 13621. Cairo 11511 - Egypt

Tel : +202 42452022

Mob : +2010 29999054 / +2010 29999056

+2010 29999057 / +2010 29999058

E-Mail : info@khedr-eg.com



www.khedr-eg.com

